

Alarms

There are three alarm conditions for the controller. When an alarm condition is detected, the display shows the condition and the audible alarm sounds. **To silence the alarm, press the alarm/set button.** The ALARM light will be lit any time an alarm condition exists. The audible alarm will also come on to indicate a momentary loss of power.

The indication “OF” shows that the tank temperature is more than 3°F above the set temperature. The display will alternately show the measured temperature for one second then the alarm condition.

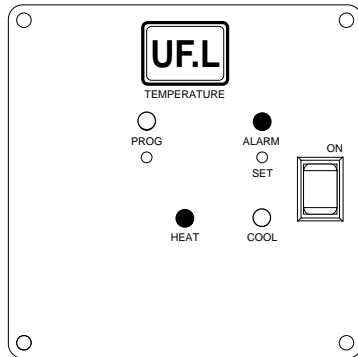
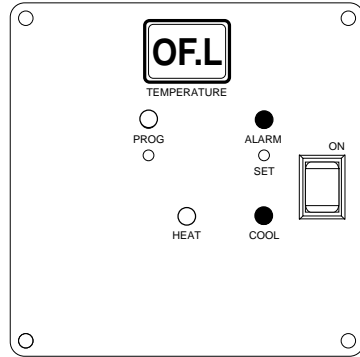

The indication “UF” shows that the tank temperature is more than 3°F below the set temperature. The display will alternately show the measured temperature for one second then the alarm condition.

The indication “SF” shows that the temperature sensor has failed or become disconnected. This will be a constant indication until the fault is corrected. When “SF” is indicated, both the heater and chiller are disabled.

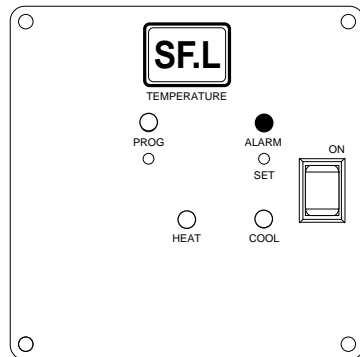

Calibration

If the sensor is replaced (see note on bottom of page 4), the unit must be calibrated. First measure the actual tank temperature with an accurate thermometer accurate to at least ± 1 degree. It should be noted that inexpensive digital and small floating thermometers are only accurate to at best 2 degrees and that liquid crystal stick-on thermometers are only good to 5 degrees. Accurate calibration thermometers are available from your Medusa dealer (Catalog #A-20).

1. Press the PROG button to enter the programming mode.
2. Adjust the set temperature by pressing the ALARM/SET button until the display shows the measured aquarium temperature.
3. Press the PROG button four times or until the display reads “CAL”.

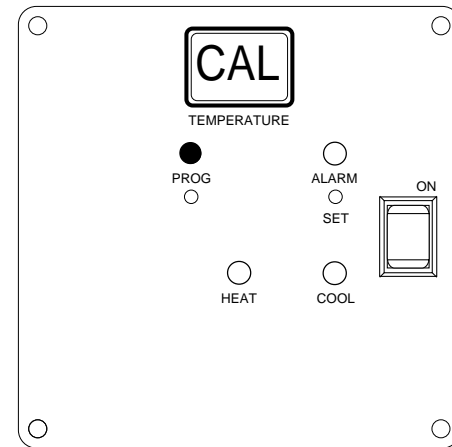

3. Press the ALARM/SET button and, while holding it down, press the PROG button. Release both buttons. The display should show the measured aquarium temperature. Now the unit is calibrated but **the set temperature needs to be reset to the desired tank temperature.** Refer to the programming section number 1 through 4 on pages 5-7 for details.

Troubleshooting

The chiller comes on more than twice per hour, or stays on less than 15 minutes.

This is usually a result of improper temperature probe placement or incorrect flow direction through the chiller. The temperature probe must measure the tank water temperature not the temperature of the chiller coils. In some flow-through chillers, the temperature probe is placed at the inflow of the chiller. If the flow is reversed from the direction specified by the manufacturer, the probe will be measuring the temperature of the chiller coils instead of the tank water. With drop-in units, the temperature probe should be located in the tank as far away as possible from the discharge into the tank. If the chiller circulates water through the sump instead of being in line to the tank, the temperature probe should be placed as for a drop-in unit. If the chiller cycles too rapidly, try first moving the temperature probe. If this does not solve the problem, try placing a 6" long piece of 1/2" PVC pipe over the probe to isolate it from water currents. With flow-through units, the flow through the chiller needs to be at least that suggested by the manufacturer. If the flow is low, the chiller will not cool properly and may be damaged.

The chiller is on most of the time or does not keep the tank at temperature.

This is a result of the chiller being the wrong size for the tank, a pump problem, or the chiller not operating at full capacity. If the chiller has worked properly before, clean the condenser and, if required, the cooling coils (see routine maintenance). Check the pump to make sure that it is open and delivering the required flow to the chiller. If this does not help, the chiller needs service.

The temperature on the display does not match the thermometer.

This could be a result of temperature differentials between where the thermometer and temperature probe are located, long term drift in the temperature probe, replacement of the probe, or loss of calibration. Recalibrate the unit according to the directions in the calibration section.

Contents

Introduction	1
Specifications	2
Installation	4
Programming	5
Alarms	8
Calibration	9
Operation	10
Chiller and controller placement	10
Probe placement	10
About chillers	11
Selecting a chiller	11
Plumbing the chiller	12
Flow requirements	12
Venting the chiller	14
Chiller capacity and cycle time	16
Routine chiller maintenance	17
Troubleshooting	18
The chiller comes on more than twice per hour	18
The chiller is on most of the time	18
The display does not match the thermometer.	18
The alarm is on for no apparent reason.	19
Troubleshooting Medusa TC-250	Back page

Operation

Chiller and controller placement

The chiller and controller must be placed in a well ventilated area. They cannot go into a closed cabinet. All of the heat removed from your tank plus the heat generated by the compressor in the chiller is released by the chiller. This means that a 1/4 hp chiller will need to eliminate over 5,000 BTU's from its area. To put this into perspective, a home central heating unit generates 25,000 to 50,000 BTU's. It is not recommended that a chiller be installed inside a cabinet that contains a sump or wet/dry filter unless a partition is installed as in Figs. 1 and 2 on page 13. It is best to have the chiller freestanding outside the cabinet to allow the maximum air flow. The air flowing through the chiller and around the controller **MUST NEVER EXCEED 35°C OR 95°F**.

The controller needs to be mounted to a vertical surface where it will not be splashed with water. It must never be laid on the bottom of the cabinet or on the floor. It should be placed so that the display and buttons are easily accessible.

Note: To prevent damage to the controller and to reduce the risk of shock, *never* press programming buttons when your hands are wet.

Probe placement

The placement of the temperature probe may be critical to the proper operation of the controller. If the probe is installed directly in the chiller, the only thing to check is that the flow direction is correct. With drop-in units, the temperature probe should be located in the tank as far away as possible from the discharge into the tank. If the chiller circulates water through the sump instead of being in line to the tank, the temperature probe should be placed in the aquarium away from the water return line coming from the chiller.

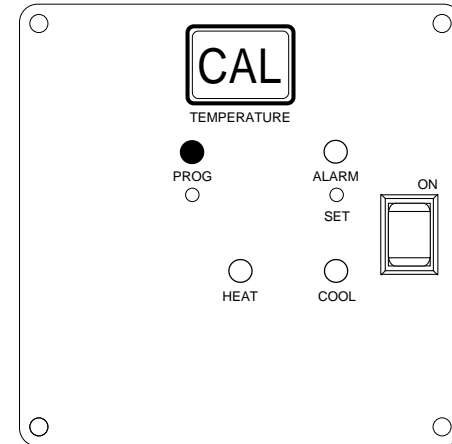

Display indicating calibration mode.

4. The controllers are calibrated at the factory. **There is no need to calibrate a new controller.** Calibration is only necessary if the temperature sensor is replaced (see page 9). Press the PROG button to exit the programming mode. The yellow light should now be off indicating programming is complete.

5. Replace the clear snap-on cover to protect your Medusa controller.

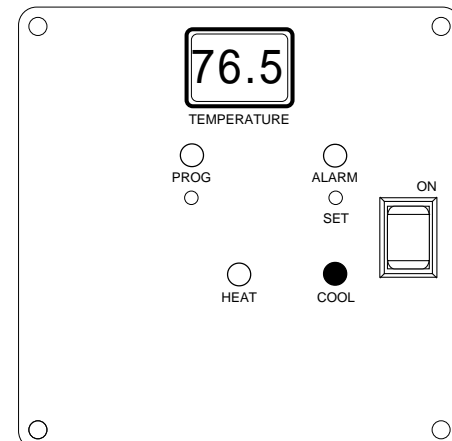

The yellow PROG light is off indicating normal operating mode with the display showing aquarium temperature.

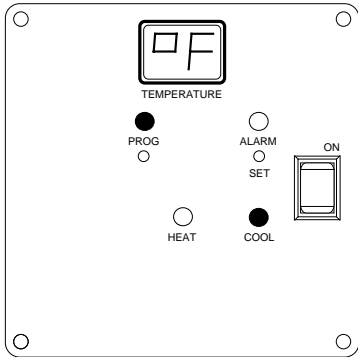

Display indication for degrees Fahrenheit.

When the desired temperature units are shown, press the PROG button to move to the next programming function, selection of heat or cool operation.

2. The display shows the **temperature units**. Pressing the ALARM/SET button will cause the units to change.

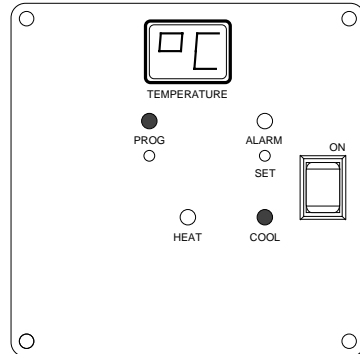

Display indication for degrees Celsius.

3. The display shows the control function. Pressing the ALARM/SET button will cause the function to change between HE for heat and CO for cool.

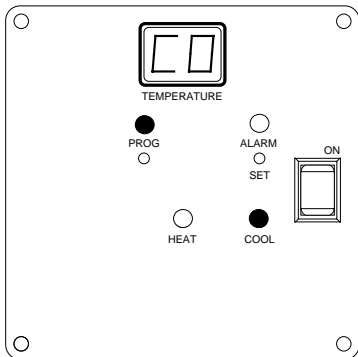

Display indicating a chiller is controlled

When the desired control function is shown, press the PROG button to move to the next programming function, calibration.

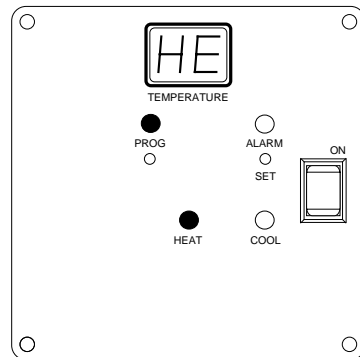

Display indicating a heater is controlled

About Chillers

Chillers come in several sizes rated in horsepower. Table 1 shows the typical cooling power and minimum required flow-rate for the most common chiller sizes. The value of interest in the table is the heat capacity. This is specified in British Thermal Units, BTU for short.

TABLE 1

HP	BTU*	MINIMUM FLOW	
1/6	1,550	3	GPM
1/5	2,350	4.5	GPM
1/4	3,000	6	GPM
1/3	4,000	8	GPM
1/2	6,000	12	GPM

*The BTU ratings are nominal, manufacturer's ratings will vary.

**Flow rate is determined for 1°F difference between in and out flows. GPM = gallons per minute.

The heat capacity required for any tank is a function of the amount and type of lighting, the pumps used, the type and size of tank, the temperature of the room, and the size and type of additional equipment such as UV sterilizers and protein skimmers. Table 2 shows the average tank size for different chiller sizes and required temperature decrease. This is a general guide only. **If there is any question, select the next bigger chiller size.**

Selecting a chiller

To use Table 2, select the degrees you wish to lower your tank temperature from the top line and follow the column down to the size of your tank in gallons. Now follow this row to the HP column to find the size chiller you need. Example: If you have a 100 gallon tank and you wish to lower it 15° then you would need a 1/4 hp chiller.

TABLE 2
TANK SIZE IN GALLONS
PULL DOWN*

HP	10°F	15°F	20°F	° temp
1/6	50	40	30	gallons
1/5	75	60	55	
1/4	120	100	80	
1/3	220	185	140	
1/2	320	250	185	

*Pull down is the maximum reduction in aquarium temperature that your system will need.

Plumbing the chiller

There are two different ways to plumb a flow-through chiller. The recommended method is putting the chiller in line with the water return to the tank. This does not require an additional pump and allows for the best temperature control. All filtering should occur before the water enters the chiller. This will reduce organic buildup inside the chiller.

The second method pumps water through the chiller from and back into the sump. This requires an additional pump and reduces the accuracy of the temperature control. It may also increase the organic buildup inside the chiller if the water entering the sump is not pre-filtered.

Flow requirements

The direction and volume of flow through the chiller needs to be correct for proper operation. The flow rate through the chiller determines the temperature difference between the water flowing into and out of the unit. Too low of a flow will result in cold water being returned to the tank. This will produce cold currents and temperature separation in the tank and may cause discomfort to the tanks occupants. Low flow will also reduce the efficiency of the chiller and may reduce its life.

Programming

Programming the controller involves setting the desired temperature, setting the temperature units, (degrees C. or F.), selecting the heat or the chill mode and, if required, calibrating the temperature. Prior to programming, turn the TC-250 on and let it warm up for 10 minutes.

Note: To prevent damage to the controller and to reduce the risk of shock, never press programming buttons when your hands are wet.

1. To enter the programming mode, remove the clear snap-on cover and press the PROG button.

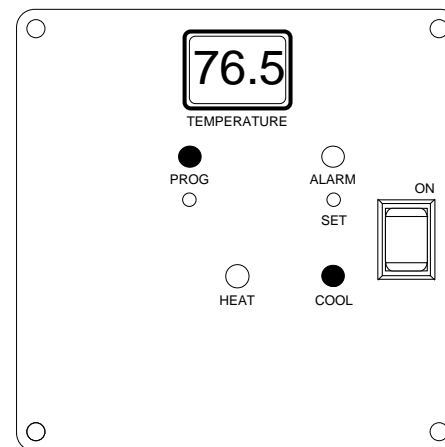

The display will show the current **set temperature** and the yellow PROG light will come on. To change the set or desired temperature, press the ALARM/SET button. Pressing it once will cause the set temperature to increase by one degree. If the ALARM/SET button is held in, the set temperature will increase at a 0.3 degree per second rate for the first 3 seconds and 3.0 degrees per second thereafter. When the set temperature reaches 90.0°F or 32.0°C, it will “roll over” to 32.0°F or 0.0°C. When the desired temperature is displayed, press the PROG button to go to the next programming function, **temperature units** (°C or °F).

Installation

1. Place the Medusa Model TC-250 controller in a dry location where it will not be subject to water splash. Do not put the TC-250 in a humid aquarium cabinet since salt mist will damage the electronics. Attach the controller to a vertical surface by placing screws through the holes on the mounted flanges.
- 2a. If the TC-250 is to be used with a heater, set your aquarium heater thermostat $10\frac{1}{2}^{\circ}\text{F}$ above the desired aquarium temperature and plug it into the receptacle on the bottom of the Model TC-250 controller.
- 2b. If the TC-250 is to be used with a chiller, set your chiller thermostat $10\frac{1}{2}^{\circ}\text{F}$ below the desired aquarium temperature (if your chiller has a self-contained thermostat) and plug it into the controller receptacle.
3. Insert the sensor wire jack into the RCA receptacle on the bottom of the controller and, if it is not already installed and place the temperature sensor in a non-turbulent area towards the bottom of the aquarium. Secure it so it will stay in place.
4. Plug the controller power cord into any standard 15 amp grounded GFI-protected wall receptacle and press the controller power switch to the “on” position. The display should now be illuminated.
5. **Note:** Chillers larger than 1/5hp should have their own dedicated 15 amp circuit. Only the chiller should be on this circuit.
6. If an extension cord is used, it should be a 15 amp (#14 wire) or 20 amp (#12 wire) cord. Cords should be as short as possible to prevent excessive voltage drop.

IMPORTANT NOTE: Insert the sensor cord into the RCA jack on the bottom of the HC-100 with a twisting motion. Make sure the cord jack is seated tightly against the black temperature sensor grommet. See figure on page 3.

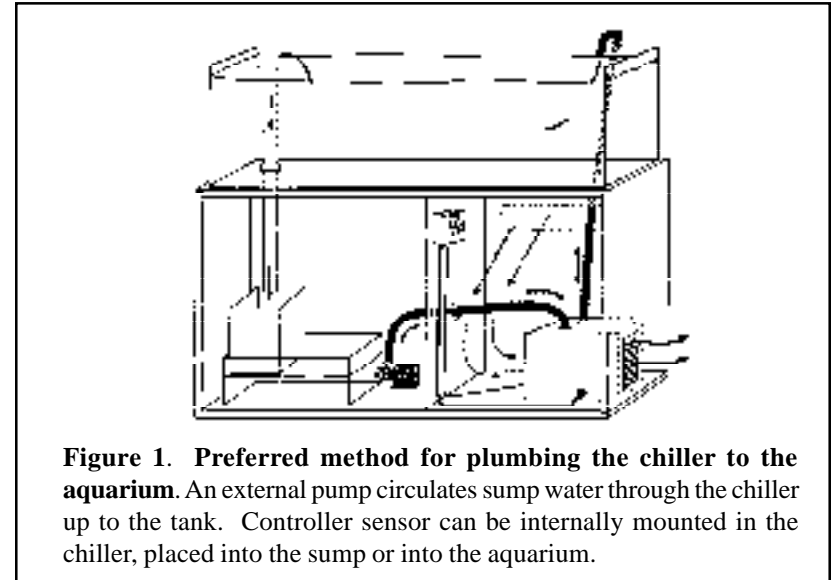

Figure 1. Preferred method for plumbing the chiller to the aquarium. An external pump circulates sump water through the chiller up to the tank. Controller sensor can be internally mounted in the chiller, placed into the sump or into the aquarium.

Note: In either installation, the chiller and controller are placed in a well-ventilated area partitioned off from the sump to prevent corrosion from high humidity or salt-laden air.

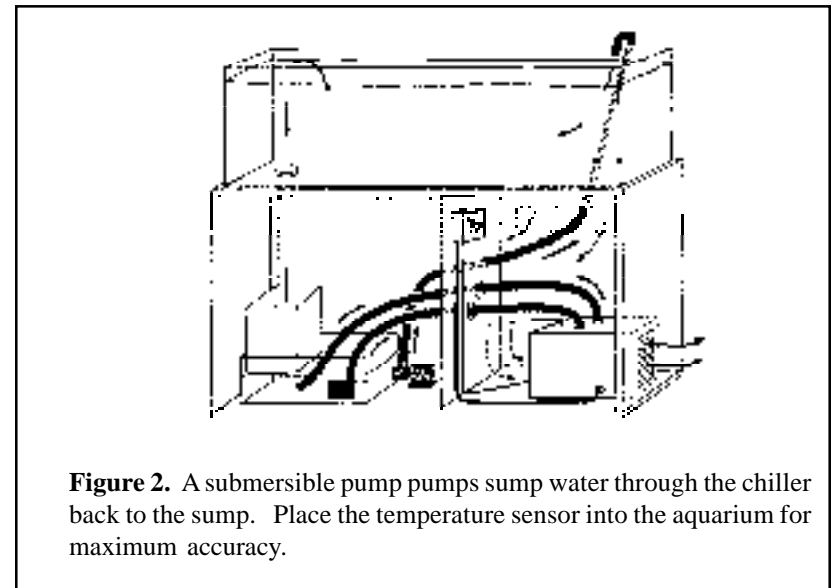
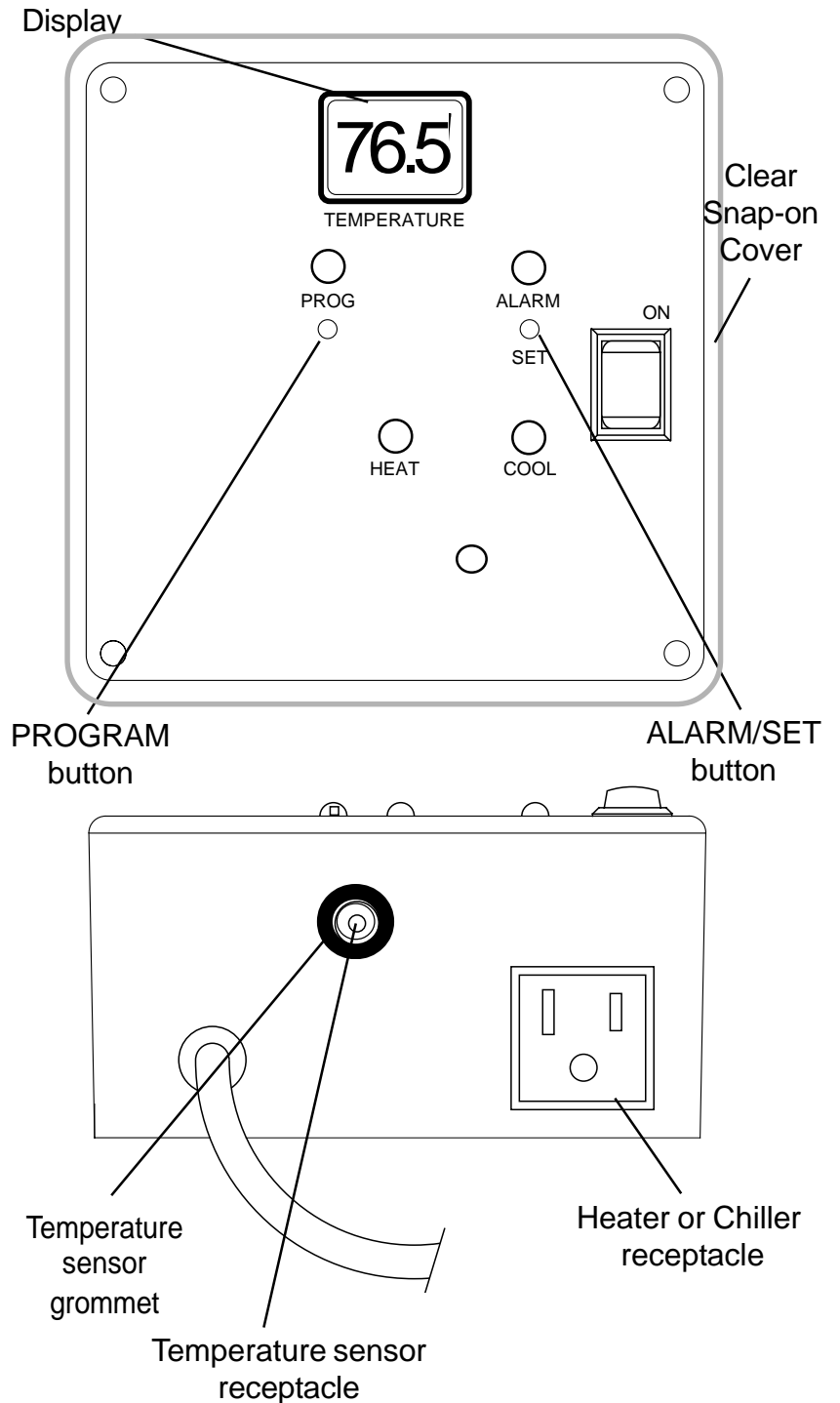
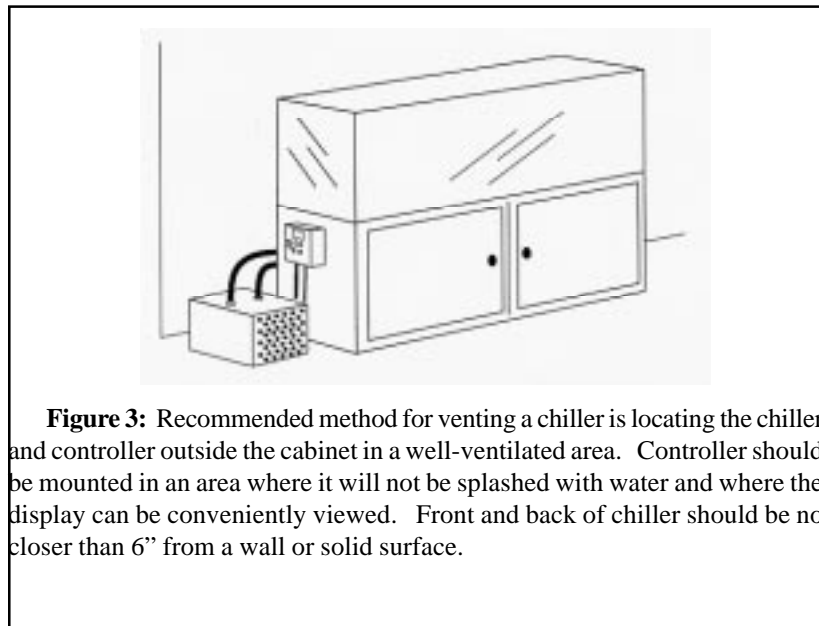

Figure 2. A submersible pump pumps sump water through the chiller back to the sump. Place the temperature sensor into the aquarium for maximum accuracy.

Venting the chiller

For optimal chiller performance, the chiller should be installed outside of the aquarium cabinet. If a sump or wet dry filter system is installed in the cabinet, the chiller and controller must be placed outside of the cabinet to prevent corrosion damage unless a partition is installed (see Figs. 1 and 2 on page 13). If the chiller is to be placed inside the cabinet, special care must be taken to remove the heat produced by the chiller. (A 1/4 hp chiller will produce as much heat as a 1,000 watt electric space heater!) Failure to remove this heat will cut down on the cooling capacity of the chiller, shorten its life, and void the warranty. The air temperature inside a properly vented cabinet should be no warmer than 5°F above room temperature. **Small computer type fans are insufficient to remove the heat produced by chillers.**



Specifications

Display

Display type	3 digit .36 inch high LED
Display resolution	±1 degree
Calibrated display accuracy	± .1 degrees
Display units	°F or °C, selectable

Alarms

Deviation to activate alarm	±3 degrees F.
Sensor fail criteria	open or short
Display indications	high temperature = OFL low temperature = UFL sensor failure = SFL

Sensor

Sensor type	semiconductor, voltage output
Sensor drift	.075°C in first 1000 hrs.
Cord	6 foot long with RCA phono jack connector

Control

Heater turn on point	set point - .8°F.
Heater turn off point	set point + .4°F.
Chiller turn on point	set point + .8°F.
Chiller turn off point	set point - .4°F.
Control point drift	±.2°F. max
Calibration accuracy	±0.2°F. or °C. depending on selected units when calibrated

Outputs

Chiller	1/2hp max. load at 115 VAC
Heater	1200 watts max load at 11V5 VAC
Receptacles	NEMA 15P grounded outlets
Power rating	15 amps max., 105-130VAC, 49-61 Hz.

Environmental

Ambient temperature	32 to 95 degrees F. (0 to 35 degrees C.)
Relative humidity	0-90% non-condensing

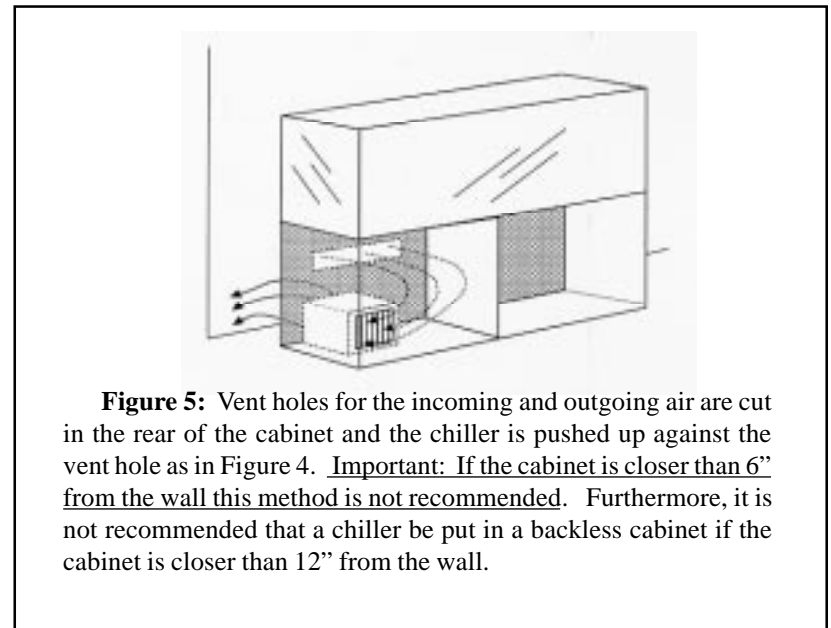
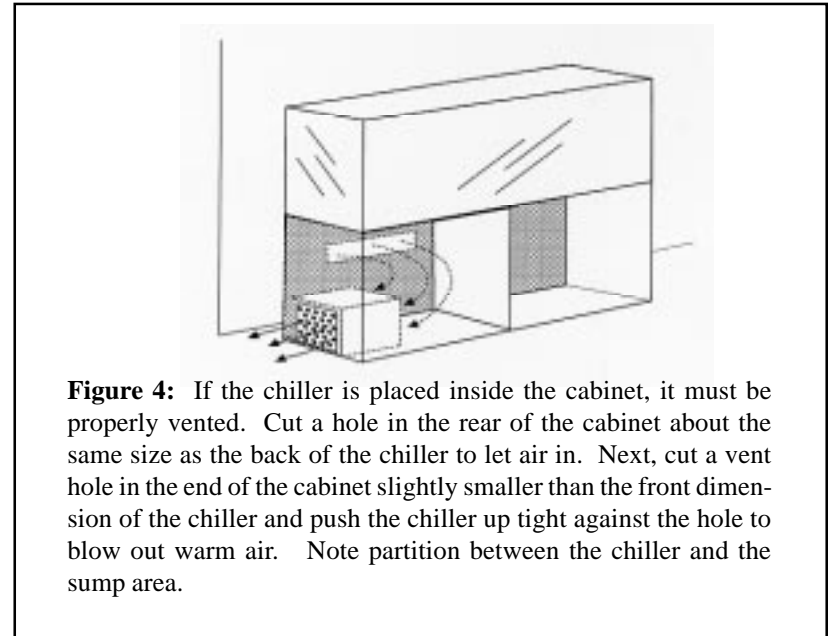

Chiller capacity and cycle time

The chillers are rated in BTU's. This stands for British Thermal Units and is the heat required to raise one pound of water one degree Fahrenheit. Seawater weighs about 8.5 pounds per gallon. A 50 gallon tank will contain about 45 gallons or 383 pounds of water and 100 pounds of rock and gravel. This all together will require 450 BTU's to heat one degree or the removal of 450 BTU's to cool one degree.

There are several sources of heat that increase the temperature of the water. These include the pumps, lighting, and conduction from the air in the room if the room temperature is above that of the tank. These heat sources can be rather significant. A small power head pump or a UV unit produces 50 BTU's, a 600 gpm main pump can produce 350 BTU's, and the lighting can generate over 1000 BTU's. A typical 50 gallon tank without high intensity lighting will have as much as 750 BTU's of heat input without considering conduction from the room.

A typical 1/4 hp chiller will remove 2,400 BTU's of heat from the tank per hour while it is running. With the 750 BTU heat input for a typical 50 gallon tank, there is 1,650 BTU (2,400 minus 750) per hour available to reduce the water temperature. This will drop the temperature 3.7 degrees per hour. Since the TC-250 turns the chiller on until it lowers the aquarium temperature 1.2°F, the chiller will stay on for 20 minutes. The heat sources heat the tank at a rate of 1.6 degrees per hour giving about 43 minutes to raise the temperature to the point where the chiller comes on.

Important: If the chiller comes on more than twice per hour or stays on less than 15 minutes, there is a problem. Please refer to Troubleshooting on page 18.

Introduction

Thank you for selecting the Medusa Model TC-250 heater or chiller controller. Medusa controllers use high quality components and the most advanced microprocessor circuitry to ensure accurate and reliable temperature control vital to today's advanced aquarium systems using either a heater or a chiller*. The Model TC-250 will support up to a 1/2 hp chiller or 1,200 watts of heaters.

The Medusa Model TC-250 is a multifunctional controller. It is a digital thermometer, controls aquarium temperature, and sounds an audible alarm when the temperature varies 3½F from the set point or if the temperature sensor fails or becomes unplugged. The easy-to-read LED display can easily be set to read in Celsius or Fahrenheit degrees. LED operating lights indicate the Medusa Model TC-250's current operation mode:

Program Mode=	Yellow Light
Alarm Mode	= Red Light
Chiller On	= Green Light
Heater On	= Orange Light

The heat or cool set point is set by a single digital adjustment with a range of 32 to 90 degrees Fahrenheit or 0 to 32 degrees Celsius. The heater will come on at .6 degrees below set point and stay on until the temperature rises to .6 degrees above the set point. The chiller will come on at .6 degrees above the set point and will stay on until the temperature drops to .6 degrees below the set point. For example, if the TC-250 is in the chill mode and set to 75.0°F, the chiller will come on when the aquarium heats up to 75.6°F and turn off when the chiller has cooled the aquarium down to 74.4°F.

**The TC-250 can be used to control air temperature in greenhouses, coldrooms etc. by removing the rubber end-cap from the stock A-35 temperature sensor.*

Routine Chiller Maintenance

Chillers are generally rather maintenance free. The only thing that needs to be done to them is to vacuum the dust from the condenser coils. That is the part of the unit that looks like a car radiator and should be done at least once a month. If the coils are not kept clean, the cooling capacity will be reduced and the unit may be damaged. If the water flowing through the chiller is not filtered to about 20 microns, there may be some buildup of organic matter inside the chiller. This buildup can only be cleaned as follows:

- a) Remove the chiller from the system and flush with fresh water.
- b) Completely drain the heat exchanger.
- c) Fill the heat exchanger with a 50% Chlorox solution and let stand for 30 minutes.
- d) Flush the heat exchanger with fresh water for at least 5 minutes.
- e) Completely drain the heat exchanger.
- f) Fill the heat exchanger with any dechlorinator and allow to stand for 5 minutes.
- g) Flush the heat exchanger with fresh water for at least 2 minutes.
- h) Drain the heat exchanger.
- i) Replace the chiller into the system.

If in-line filter canisters are used, the cartridges must be cleaned regularly. A dirty cartridge greatly reduces the water flow rates. **A flow meter is recommended to monitor the water flow rate through the chiller and to insure the proper minimum flow.**

WARRANTY

Medusa Associates, Ltd. warrants its products for parts and labor for a period of one year from the date of purchase. This covers normal use of the equipment only. Any use other than that intended, misuse, abuse, or customer modification will void this warranty. Medusa, at its option, will repair or replace equipment failed because of defects in either workmanship or parts. **Shipping to and from the factory will be at the customer's expense.** Under no circumstances will Medusa be responsible for any incidental damage or expense resulting from the use of the equipment covered by this warranty.

Specific Exclusions

The following events specifically void the warranty.

1. Splashing with or immersion in water
2. Operation in an improperly vented cabinet
3. Service by unauthorized persons

TO REDUCE RISK OF DEATH BY ELECTRICAL SHOCK:

1. FOR INDOOR USE ONLY
2. Mount unit securely where unit cannot be splashed with or immersed in water.
3. Unplug unit when not in service or being serviced.
4. Connect unit to GFI-protected circuit only.
5. Read instructions before operating.
6. Unit contains no user serviceable parts. Unit can only be serviced by qualified persons.

The alarm is on for no apparent reason.

This usually indicates that there has been a momentary power outage. The alarm can be silenced by pressing the ALARM/SET button. Recheck the set point to verify correct operation.

Accessories

A-20: Precision Calibrating Thermometer

Range 66°F-80°F. Mercury thermometer with 0.2°F increments for accurate calibration of Medusa controllers.

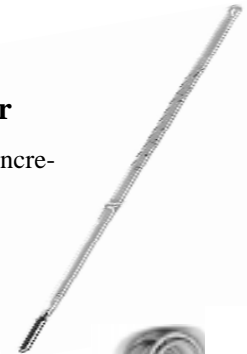

A-35: Combination Temperature Sensor:

Used for in-water or in-air applications. Leave rubber end-cap on for in-water use. Remove end-cap for in-air use. Comes with 6 foot cord.



A-50: RCA Sensor Extender Cord:

Adds 6 feet of length to temperature sensor A-35.

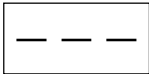

MEDUSA TC-250 TROUBLESHOOTING GUIDE

PROBLEM	CAUSE	SOLUTION
Display reads higher or lower than actual aquarium temperature.	Temperature sensor too close to heater or chiller return stream.	Move temperature sensor.
	Temperature sensor has been replaced or unit has lost calibration.	Recalibrate controller and reset set point.
Temperature display never changes.	Unit is in the Program mode	Press PROG button until yellow PROG light turns off.
Display reads: 	Unit has lost calibration.	Recalibrate controller and reset set point.
Red heat or green chill light is on but heater or chiller either do not operate or will not turn off.	Heater or chiller are plugged into the wrong controller receptacles.	Plug heater into left Medusa receptacle on bottom of controller and plug chiller into the right receptacle.
Red heat or green chill light is on but heater or chiller will not turn on.	Heater and/or chiller thermostats (if present) are set incorrectly.	Set heater thermostat 10° above desired aquarium temperature and chiller 10° below.
	Heater or chiller defective.	Service or replace heater or chiller.

Operating instructions

Medusa Model TC-250

Heater or Chiller Temperature Controller



Distributor of
Medusa Aquarium Products

740 Tioga Avenue, Sand City, CA 93955
 TEL (831) 394-0828 • FAX 831-899-3399
www.sealifesupply.com